

Test Jack Panel

TJ-327-02D

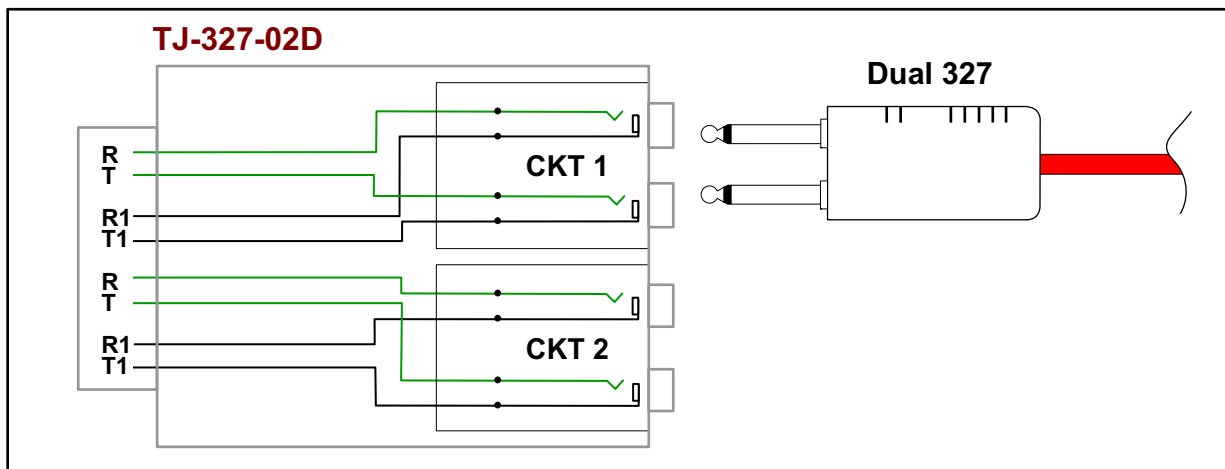

TJ-327-02D Test Jack Panel w/2 327C Jacks

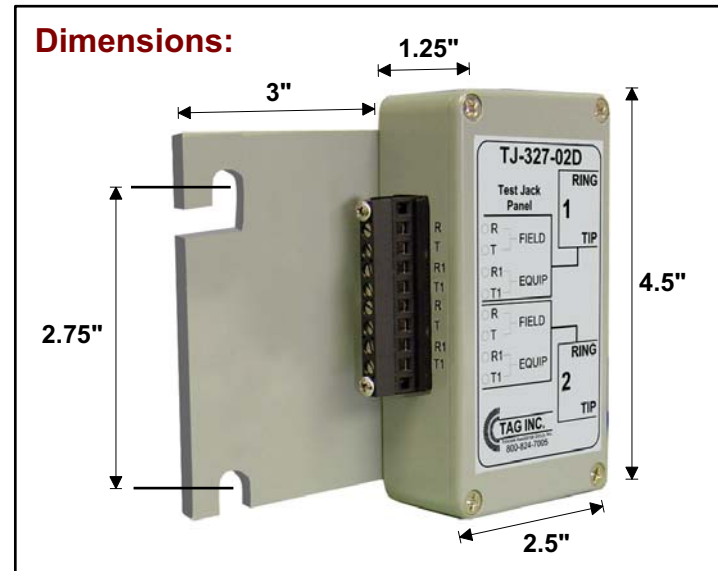

Application:

The TJ-327-02D Jack Panel provides access to (2) two independent Tip/Ring circuits using standard frame cords (Dual 327 to Protector). It conveniently mounts along the vertical side of the MDF. Connections are made to a terminal block at the rear of the unit. For additional frame cords, see page 2.

Ordering Information:

TJ-327-02D
F-TPJ-602

Test Jack Panel w/2 327C Jacks
Frame Jack Panel w/ 12 327 Jacks

Call
for Pricing

150 Cooper Rd. (F-15)
W. Berlin, NJ 08091

www.tagcords.com

Telecom Assistance Group

Telephone: (856) 753-8585
Fax : (856) 768-7645

Test Jack Panel Accessories

Cord Test Shoe - Dual Plug (327) to 463A



Part Number Length

T-W4BR-08	8'
T-W4BR-16	16'
T-W4BR-20	20'

Cord Test Shoe - Dual Plug (327) to Porta



Part Number Length

T-W4BR-P-08	8'
T-W4BR-P	16'
T-W4BR-P-20	20'

Cord Test Shoe - Dual Plug (327) to 252A/B



Part Number Length

T-4W6A-08	8'
T-4W6A-16	16'
T-4W6A-20	20'

Cord Test Shoe - Dual Plug (327) to 412A/B



Part Number Length

T-4W11A-08	8'
T-4W11A-16	16'
T-4W11A-20	20'

Cord Test Shoe - Dual Plug (327) to Wire Wraps



Part Number Length

400327WP-08	8'
400327WP-16	16'
400327WP-20	20'

150 Cooper Rd. (F-15)
W. Berlin, NJ 08091

www.tagcords.com

Telephone: (856) 753-8585
Fax : (856) 768-7645

Telecom Assistance Group